



DUST SEPARATOR DSA-38



Removes dust and foreign matter from plastic pellets

Benefits

- The labor required to clean the conveying filter is significantly reduced.
- Improves part quality by removal of dust and foreign matter.

Product outline

- Installation is as simple as connecting to a raw material conveying hose - Inner diameter 38 mm (1 ½").
- The collected powder accumulates in the lower bucket.
- Able to use any raw material conveying equipment, such as a dryer, by any manufacturer.

Contact us for testing!

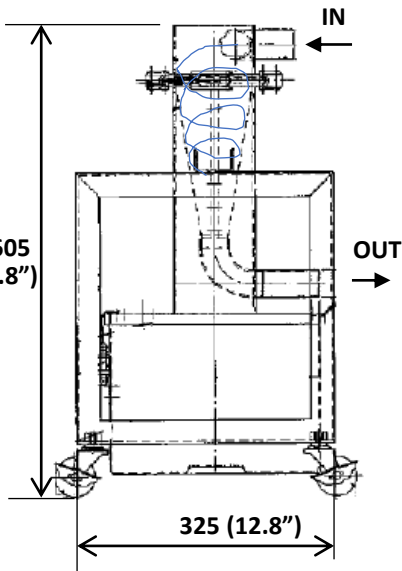

Kawata U.S.A., Inc.

712 W Algonquin Rd. Arlington Heights, IL 60005

847-379-1440 support@kawata-usa.com

www.kawata-usa.com